

## HP SERIES

WesFlo® HP Series ASME (U or UM)  
Filter Vessels for High Pressure  
Industrial and Chemical Process  
Applications

### APPLICATIONS

Cutting Oils

Lubricants

Chemicals

Solvents

Process Water

Coolants

Hydraulic Oils

Compressed Air & Gases

Other High Pressure Liquids

Catalyst Recovery

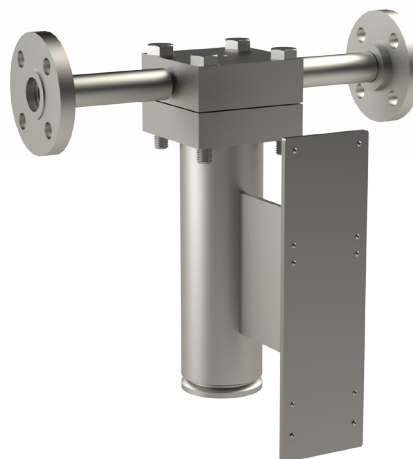

WesFlo® HP Series cartridge filter vessels are designed to deliver excellent filtration in high pressure applications up to 1610 psi, all aspects of design, materials, construction and workmanship of the HP Vessel Series conform to ASME code. (Also available in non-ASME code design and construction.)

### BENEFITS

- T-Style head and shell for ease of installation and servicing
- Non-code design and construction (parallel code standards) available
- Built in accordance with ASME (U or UN stamp) boiler and pressure vessel code
- Maximum design pressure is 1610 psi at 300°F. Higher temperature ratings available
- 1 in. connections for maximum flow capability of filter cartridges
- Available in carbon steel or 316L stainless steel
- Multiple bolt closure with bright zinc plated studs
- Buna-N standard O-ring with optional Viton®, Neoprene, EPDM and elastomers available
- Rigid cartridge support post with threaded end seal for positive double open end (DOE) cartridge seating
- Other materials available

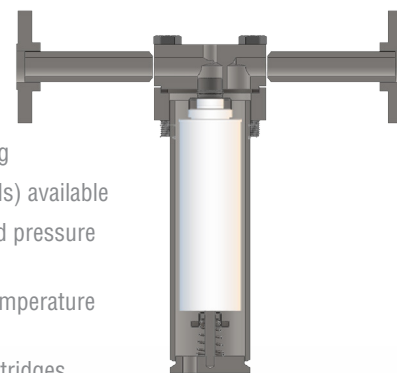

# HP

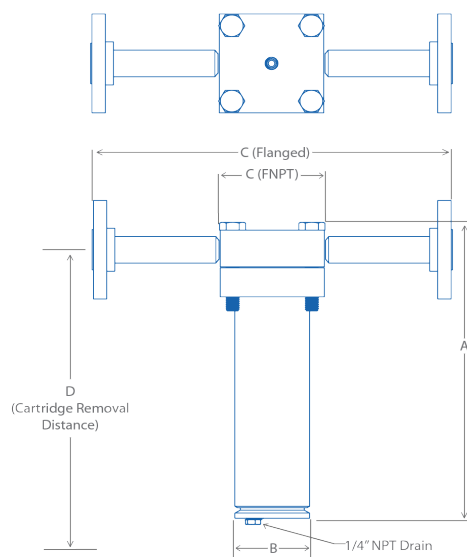

## HP

MAX DESIGN TEMPS	
CARBON STEEL	500°F (260°C)
304 SST	300°F (150°C)
316 SST	400°F (204°C)
GASKET	250°F (121°C)

CLOSURE O-RING GUIDE	
MATERIAL	MAX TEMP
NITRILE (BUNA-N)**	250°F (121°C)
EPDM (EPR)	300°F (149°C)
FKM (VITON®)	400°F (204°C)

\*\* NITRILE O-ring is standard

MODEL	PRESSURE RATING* (psi)	CONNECTION SIZE (in.)	CARTRIDGE LENGTH (in.)	DIMENSIONS (in.)				MAX GPM	SHIPPING WEIGHT (lbs)
				A	B	C	D**		
HP-11-1	1610	1-NPT	10	14.5	3.5	4.6	22	6	37
HP-1-150	245	1-FLG-150#	10	14.5	3.5	12.6	22	6	45
HP-11-1-300	665	1-FLG-300#	10	14.5	3.5	12.6	22	6	47
HP-11-1-600	1332	1-FLG-600#	10	14.5	3.5	12.6	22	6	47
HP-12-1	1610	1-NPT	20	24.5	3.5	4.6	42	12	46
HP-12-1-150	245	1-FLG-150#	20	24.5	3.5	12.6	42	12	54
HP-12-1-300	665	1-FLG-300#	20	24.5	3.5	12.6	42	12	56
HP-12-1-600	1332	1-FLG-600#	20	24.5	3.5	12.6	42	12	56
HP-13-1	1610	1-NPT	30	34.5	3.5	4.6	62	18	55
HP-13-1-150	245	1-FLG-150#	30	34.5	3.5	12.6	62	18	63
HP-13-1-300	665	1-FLG-300#	30	34.5	3.5	12.6	62	18	65
HP-13-1-600	1332	1-FLG-600#	30	34.5	3.5	12.6	62	18	65

\*Actual flow rate is dependent on fluid viscosity, micron rating, contaminant and media type. Consult flow charts for each application.

\*\*Add 3 in. when using TC internal option for use with TC style 2-222 O-ring cartridges.

Note: NPT maximum pressure is 1610 psi at 300°F with EPR O-ring, 400°F with Viton® and FEP encapsulated Viton® O-ring and 500°F with FEP encapsulated silicone. Flanged units are based on ANSI B16.5 pressure at 250°F

## ORDERING INFORMATION

MATERIAL		DESIGN SERIES		HIGH PRESSURE SERIES		CARTRIDGE QTY		LENGTH		INLET / OUTLET		CONNECTION TYPE		INTERNAL OPTION	
<b>OMIT</b>	CARBON STEEL	<b>OMIT</b>	ASME U-STAMP	<b>HP</b>	1 CARTRIDGE	<b>1</b>	10 in.	<b>1</b>	1 in. ANSI	<b>OMIT</b>	FNPT	<b>OMIT</b>	CENTER POST FOR DOE	<b>222</b>	222 O-RING ADAPTER
<b>6</b>	316 SST	<b>N</b>	NON-CODE				20 in.	<b>2</b>		<b>150</b>	150# FLANGE				
							30 in.	<b>3</b>		<b>300</b>	300# FLANGE				
										<b>600</b>	600# FLANGE				

Note: Buna-N O-ring standard. Other gasket material available.



25110THOMASDR  
WARREN, MI 48091  
P: 586-427-7700 F: 586-427-7895  
www.aatanks.com